



## Description

This is a commercial grade low voltage ceiling mount sensor that operates lights using passive infrared (PIR) technology. The sensor features a 360° field of view fresnel lens that provides up to 1200 sq.ft. of coverage area. This ceiling mounted sensor operates lights ON/OFF based on occupancy and ambient light levels detected in the area. Ambient light level detection prevents the occupancy sensor from turning lights ON when the ambient light levels are sufficient. Both the time delay and light level settings can be easily adjusted. This ceiling sensor is compatible with either LED or fluorescent lights. This ceiling mount motion sensor is ideal for use in offices, classrooms, warehouses and other commercial areas.

REQUIRES DLCS-PP-ND POWER PACK

Model Number	DLCS-SN-LINE-ND
Operating Voltage	Low
Load Ratings	15A
Load Types	LED
Dimming Compatibility	Low Voltage
Mounting	Ceiling
Sensing Technology	PIR
Coverage	360 degree
Warranty	5 year



## Coverage Patterns

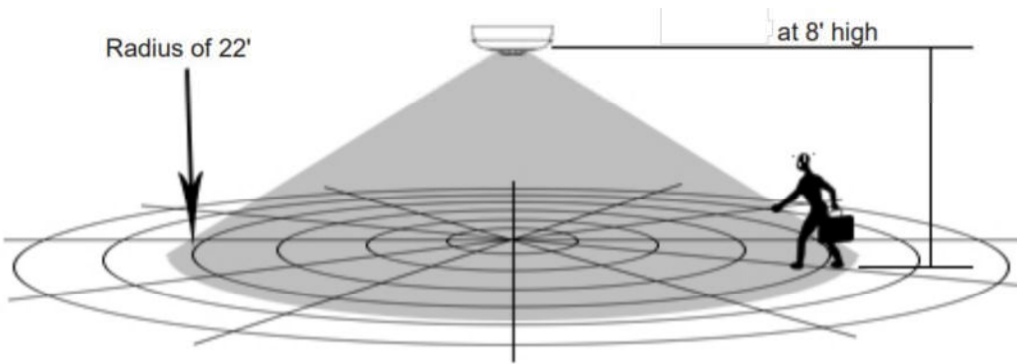

The SN Line provides a 360° coverage pattern, up to 1200 square feet. The diagram below shows the range of detection with the sensor mounted at a height of 8 feet. The sensor is designed to detect a heat-emitted movements across its range of view. Obstructions and low levels of movements may hinder the level of detection.

## Wiring Diagram

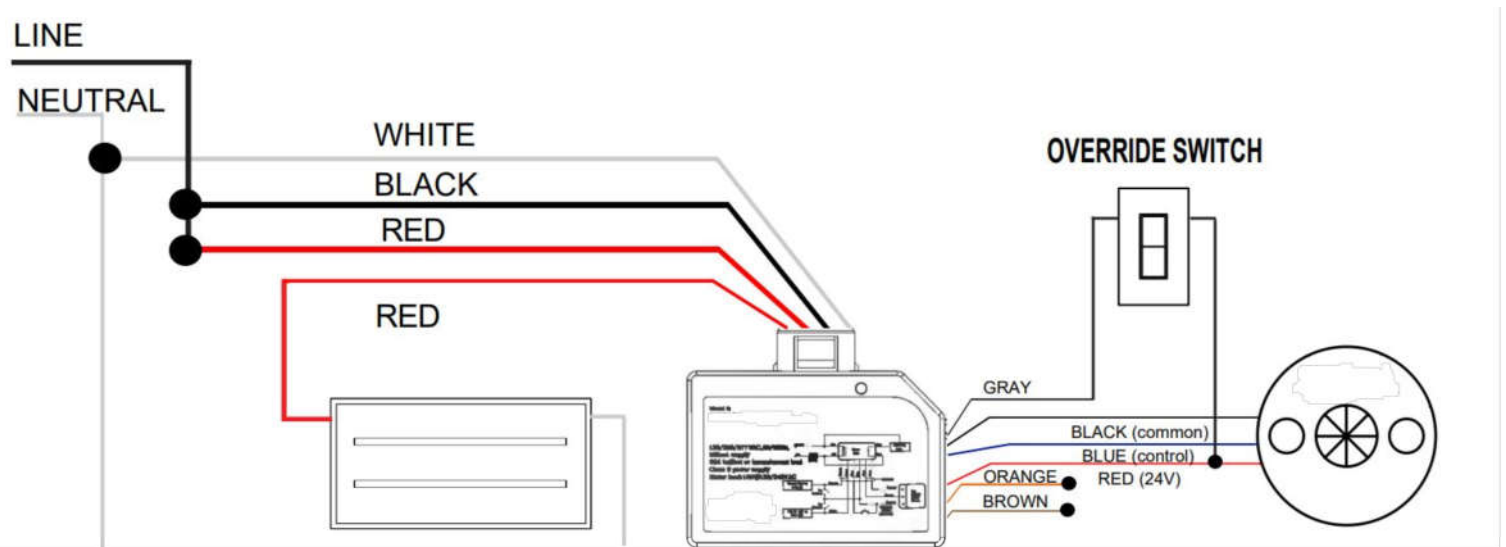

# Line Drawings

